

# Refrigerator

Instructions for installation and use

**SA 300 I**

 **INDESIT**



**GB** 0-star refrigerator

Instructions for installation and use



**To maintain the EFFICIENCY and SAFETY of this appliance, we recommend:**

- use only the MANUFACTURER Service
- use only ORIGINAL Spare Parts

# Safety - a good habit to get into.

## ATTENTION

*Read your manual carefully since it contains instructions which will ensure safe installation, use and maintenance of your appliance.*

*Your Refrigerator is built to International safety standards (EN60) and has been awarded the European approval mark (IMQ) for compliance with UK electrical safety requirements. It also meets the EC standards on the prevention and elimination of radio interference (EC directive 87/308 - 02.06.89).*

- 1.** This appliance must not be installed outdoors - not even in an area protected by a roof. It is extremely dangerous to leave it exposed to rain or storms.
- 2.** It must only be used by adults and exclusively to refrigerate and freeze foodstuffs, following the instructions for use contained in this manual.
- 3.** Do not ever touch or handle the appliance with bare feet or with wet hands or feet.
- 4.** It is highly recommended that you do not use extension cords or multiple socket adapters. If the refrigerator is installed between cabinets, make sure that the cord is not bent or dangerously pinched or compressed.
- 5.** Never pull on the cord or the refrigerator to remove the plug from the wall socket - this is very dangerous.
- 6.** Never touch the cooling components within the appliance, especially with wet hands because this could result in injury. Never put ice cubes just removed from the freezer into your mouth because they could stick to your mouth and cause burns.
- 7.** Never clean or perform maintenance on the appliance without first removing the plug from the socket; in fact, turning the knob for adjusting the temperature to the ● setting is not sufficient to eliminate all electrical contact with the mains.

**8.** Before having your old refrigerator picked up for disposal, remove or make inoperable any locking devices to prevent children who might play in or around the appliance from being locked inside.

**9.** Before calling for service/assistance in the case of malfunction, consult the chapter entitled "Is There a Problem?" to determine whether it is possible to eliminate the problem. do not try to repair the problem by trying to access the internal components of the appliance.

**10.** If the power supply cord must be replaced, please contact one of our Customer Service Centers. In some cases, the connections are made using special terminals and in others a special tool must be used to access the connections.

**11.** Do not use electric appliances inside the compartment for food storage, if these are not those recommended by the manufacturer.

**12.** At the end of the functional life of your appliance – containing cyclopentane gas in the insulation foam and perhaps gas R600a (isobutane) in the refrigeration circuit – the latter should be made safe before being sent to the dump. For this operation, please contact your dealer or the Local Organisation in charge of waste disposal.

# Installation

**To ensure that the appliance operates properly and to reduce energy consumption, it is important that the appliance is installed correctly.**

## Ventilation

The compressor and condenser generate heat and, therefore, need to be ventilated properly. Rooms with less than perfect ventilation are not very suited for installation of the appliance. Therefore, it should be installed in a room with an opening (window or French window) that provide the appropriate amount of air re-circulation. It is also important that the room not be too humid.

During installation, make sure not to cover or obstruct the grates that allow for proper ventilation of the appliance.

For proper ventilation of the appliance, you must leave:

- a space of at least 10 cm between the top part and any cabinets above it;
- a space of at least 5 cm between the sides of the appliance and any adjacent cabinets/walls.

## Away from Heat

Avoid positioning the appliance in a place where it is directly exposed to sunlight or near an oven, cook top or the like.

## Levelling

The appliance must be level. To level the appliance properly, first adjust the front plastic feet and then unscrew the foot situated beneath the lower door hinge until it adheres to the floor completely (Fig. 1).

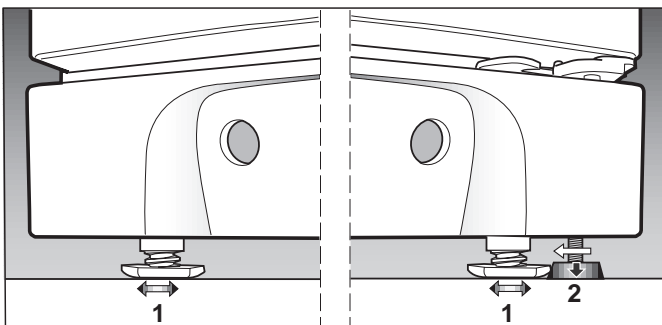

Fig. 1

## Electrical Connection and Earthing

Before proceeding with the electrical connection, make sure that the voltage indicated on the rating plate, located at the bottom left near the vegetable crisper, corresponds to the mains voltage in your home and that the socket is fitted with a standard earthing wire in accordance with safety standards for 46/90 systems. If the socket is not fitted with an earthing wire, the manufacturer will not be held liability for any damages and or injuries arising out of the use of the appliance. Do not use multiple sockets or adapters.

**Position the appliance in such a way that you can access the socket where it is plugged in.**

## Insufficient power?

The electrical socket must be able to handle the maximum power load of the appliance, which is indicated on the rating plate located at the bottom left next to the vegetable crisper.

## Before making the electrical connection ...

After the appliance has been delivered, place it in the vertical upright position and wait at least 3 hours before inserting the plug into the socket in order to ensure that it functions properly.

## Electrical connection

Your appliance is now supplied with a 13 amp fused plug that can be plugged into a 13 amp socket for immediate use. Before using the appliance please read the instructions below.

**WARNING - THIS APPLIANCE MUST BE EARTHED. THE FOLLOWING OPERATIONS SHOULD BE CARRIED OUT BY A QUALIFIED ELECTRICIAN.**

### Replacing the fuse:

When replacing a faulty fuse, a 13 amp ASTA approved fuse to BS 1362 should always be used, and the fuse cover re-fitted. If the fuse cover is lost, the plug must not be used until a replacement is obtained.

### Replacement fuse covers:

If a replacement fuse cover is fitted, it must be of the correct colour as indicated by the coloured marking or the colour that is embossed in words on the base of the plug. Replacements can be obtained directly from your nearest Service Depot.

### Removing the plug:

If your appliance has a non-rewireable moulded plug and you should wish to remove it to add a cable extension or to re-route the mains cable through partitions, units etc., please ensure that either:

- the plug is replaced by a fused 13 amp re-wireable plug bearing the BSI mark of approval
- or:
- the mains cable is wired directly into a 13 amp cable outlet, controlled by a switch, (in compliance with BS 5733) which is accessible without moving the appliance.

### Disposing of the plug:

Ensure that before disposing of the plug itself, you make the pins unusable so that it cannot be accidentally inserted into a socket. **Instructions for connecting cable to an alternative plug:**

Important: the wires in the mains lead are coloured in accordance with the following code:

Green & Yellow	- <b>Earth</b>
Blue	- <b>Neutral</b>
Brown	- <b>Live</b>

As the colours of the wires in the mains lead may not correspond with the coloured markings identifying the terminals in your plug, proceed as follows:

Connect Green & Yellow wire to terminal marked "E" or  or coloured Green or Green & Yellow.

Connect Brown wire to terminal marked "L" or coloured Red.

Connect Blue wire to terminal marked "N" or coloured Black. If a 13 amp plug (BS 1363) is used it must be fitted with a 13 amp fuse. A 15 amp plug must be protected by a 15 amp fuse, either in the plug or adaptor or at the distribution board. If you are in any doubt about the electrical supply to your machine, consult a qualified electrician before use.

### How to connect an alternative plug:

The wires in this mains lead are coloured in accordance with the following code:

BLUE	"NEUTRAL" ("N")
BROWN	"LIVE" ("L")
GREEN AND YELLOW	"EARTH" ("E")

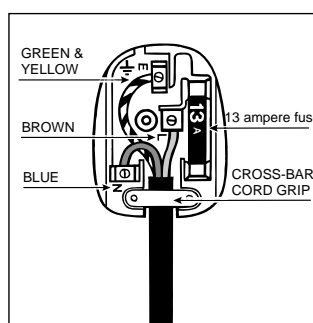

### Disposing of the appliance:

When disposing of the appliance please remove the plug by cutting the mains cable as close as possible to the plug body and dispose of it as described above.

# A closer look

## **A** Temperature regulation knob

Use this knob to regulate the temperature of the refrigerator. To following settings are available:

- refrigerator OFF;
- 1 minimum cold temperature;
- 5 maximum cold temperature

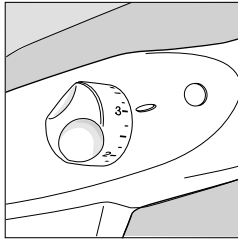

## **D** Removable door shelf for bottles

## **E** Fruit and vegetable drawer

## **F** Drainage system for defrost water

## **G** Removable height adjustable shelves

## **B** Removable shelf with lid and egg compartment

## **C** Removable door shelf for food products

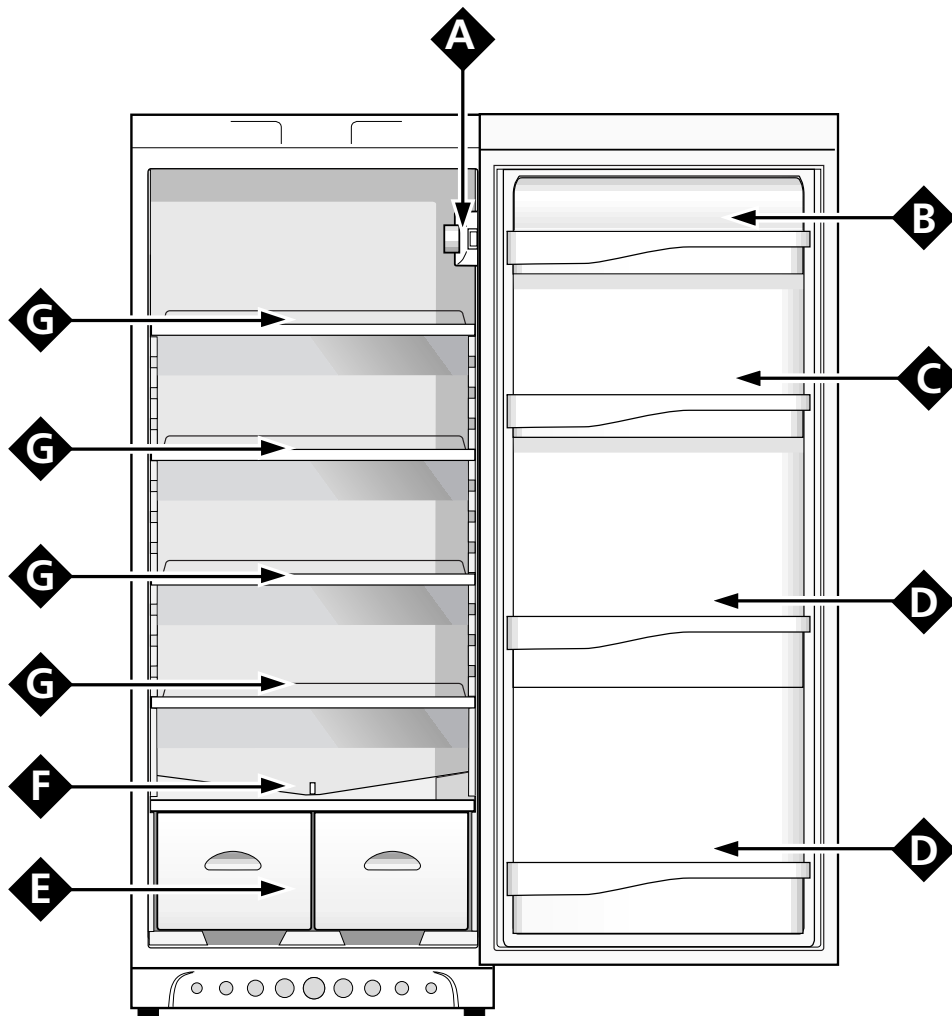

# Setting up Your Appliance

## ATTENTION

After transport stand the appliance upright and wait at least 3 hours before plugging the appliance into the mains to ensure proper performance.

Use these average temperature settings to ensure optimum performance and to save energy.

Before storing food in your refrigerator wipe the interior with a solution of warm water and bicarbonate of soda.

After having plugged the appliance into the socket, make sure that the refrigerator light has turned on. Then turn the thermostat knob "A" to setting "3". After a couple of hours, you can place fresh food into the refrigerator.

## Storage - getting the most out of your appliance

### Storing Food in the Refrigerator Compartment

Food	Storage Time	Location in the Refrigerator
Wrapped meat and cleaned fish (use plastic wrap or pack in plastic bags)	2 or 3 days	On the shelf above the vegetable crisper (which is the coldest area).
Fresh cheese	3 or 4 days	On the shelf above the vegetable crisper (which is the coldest area).
Eggs	1 month	In special egg rack on door.
Butter, margarine		On any shelf.
Cooked or precooked food (place in air-tight containers and when cool store in refrigerator)	3 or 4 days	On any shelf.
Sausages, salami, sandwich meats in general, fresh pasta, custards, puddings, chocolates, cream pastries, bread, dry pastries, red tomatoes	3 or 4 days	On any shelf.
Bottled products, milk, drinks, yoghurt		On special door shelves.
Fruits and legumes		In vegetable crisper.

### What not to store in the refrigerator

Garlic (transmits odour), onion and leeks

Bananas (these will turn black)

Citrus fruits

Potatoes and root vegetables (store in dark, dry places)

- Remember to cool hot food before storing, otherwise the temperature inside the appliance will increase, causing the compressor to work harder and use more energy.

- Air in the refrigerator circulates naturally so that cold heavier air tends to fall towards the bottom. This is why meat and fish should be stored just above the crisper.

- Remember to keep to our instructions on the storage life of foods: If not stored correctly, even the freshest food will deteriorate quite quickly.

- Please note: cooked foods do not keep longer than fresh food.

- Do not store liquids in unsealed containers since this will increase the humidity and formation of ice in the refrigerator.

- The refrigerator is equipped with practical slide-out shelves which can be adjusted for height using the appropriate guides (Fig. 2). This feature allows you to store large containers and food products.

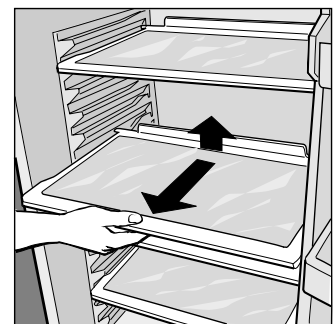

Fig. 2

## Energy Saving Tips

### - Install the Appliance Correctly

This means that the appliance should be installed away from heat sources or direct sunlight in a well ventilated room.

### - Correct Temperature Settings

Set the refrigerator temperature knob to one of the middle settings. Very cold temperature settings will not only consume a great deal of energy but will neither improve nor lengthen the storage life of the food. Excessively cold temperatures may ruin vegetables, cold cuts and cheese.

### - Do Not Overfill Your Appliance

Remember that proper storage of food requires good air circulation. Overfilling your appliance will hamper proper air circulation and overwork the compressor.

### - Keep the Door Closed

Open the refrigerator only when necessary; remember that every time you open the door most of the cold air will be lost. To bring the temperature back to the proper level, the motor must run for a considerable amount of time, consuming a substantial amount of energy.

### - Check the Seal on the Door

Keep the seal clean and soft so that it fits tightly against the door to ensure that no cold air is lost.

### - Never Put Food in the Refrigerator while Still Hot

A container of hot food in the refrigerator will increase the temperature significantly; allow food to cool to room temperature before storing.

## Caring for Your appliance

**Before doing any cleaning, disconnect the appliance from the electricity (by pulling out the plug or turning off the general switch in your home).**

### Defrosting

**WARNING: do not damage the refrigeration circuit. Do not use mechanical devices or instruments other than those recommended by the manufacturer to speed up the defrosting process.**

The evaporator defrosts automatically during operation; the defrost water is collected by the conveyor and is evaporated externally automatically.

Clean the defrost water drain hole periodically (see fig. 3) to prevent the water from collecting on the bottom of the refrigerator instead of flowing out.

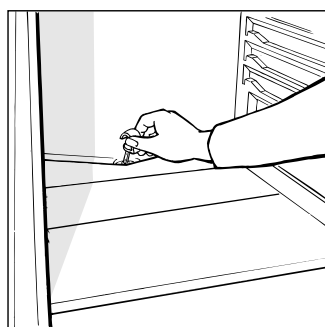

Fig. 3

nate solution, which is also a good disinfectant. If you do not have any sodium bicarbonate at home, use a neutral soap.

- What not to use: Do not use abrasive detergents, bleach or detergents containing ammonia. Never use solvent based products.

- All removable parts can be cleaned by soaking them in hot soapy water or detergent. Remember to dry them thoroughly before replacing them.

- What about the back panel? Dust may deposit on the back panel and affect the proper running of the appliance. To remove dust, vacuum away the dust very carefully using the appropriate vacuum cleaner accessory.

- Discontinued use of the appliance: If the appliance is not in use for any length of time, remember to clean the interior and dry thoroughly, leaving the door open to prevent the formation of odours and mould.

- Replacing the light bulb. The bulb for lighting the interior of the appliance is located at the back of the thermostat box. Unscrew the burned out bulb and replace it with another bulb with a wattage no higher than 15 Watt, follow the instructions illustrated in fig. 4.

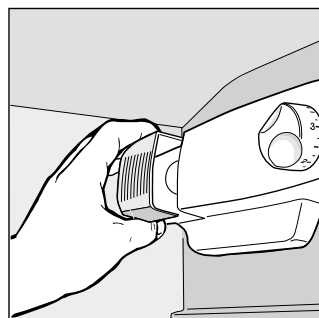

Fig. 4

### Cleaning and Maintenance

- Your appliance is manufactured with hygienic, odourless materials. To preserve these characteristics, always use sealed containers to store foods in order to prevent spills, stains and the formation of difficult to remove odours.

- Only use a water and bicarbonate solution to clean the appliance. Clean the internal and exterior of your appliance with a sponge soaked in a warm water and sodium bicarbo-



# Trouble shooting

## The appliance does not Work

Check that:

- The mains switch of your home is on;
- The plug is inserted correctly in the socket;
- The socket is working; to check this connect the appliance to another socket in the room.

## The Appliance does not Refrigerate Properly

Check that:

- The door is shut properly and that the door seal is not damaged;
- The thermostat temperature knob is on the correct setting;
- The refrigerator has not been overfilled.

## Food in the Refrigerator is too Cold

Check that:

- The thermostat knob is on the correct setting;
- Food is not touching the back of the appliance, which is very cold..

## The Motor Runs Continuously

Check whether:

- The door is not closed properly or has been left open;
- The room temperature is not too high.

## The Appliance is Noisy

Check whether:

- The appliance is perfectly level;
- The appliance has been installed between cabinets or other objects that vibrate or make noise;
- Remember that the refrigerant in the cooling circuit causes a slight bubbling sound, even when the compressor is not running (this is quite normal).

## There is Water on the Bottom of the Refrigerator

Check whether:

- The defrost drain is clogged.

If after all the checks, the appliance still does not operate or the problem persists, call the nearest Service Centre and inform them of: the type of problem, the abbreviation of the model name (Mod.) and the relative numbers (S/N) written on the rating plate located at the bottom left next to the vegetable crisper (see example in the figure below).

Mod. <b>RG 2330</b>		TI	Cod. <b>93139180000</b>		S/N <b>704211801</b>	
230 V	50 Hz	150 W	75 W	Fuse	A	Max 15
Total	<b>340</b>	<b>75</b>			Freez. Capac	Class
Gross Bruto Brut		Gross Bruto Brut	Net Util Utile	Gross Bruto Brut	Poder de Cong	Clase <b>N</b>
					kg/24 h <b>4,0</b>	Classe
Compr. Syst.	R 134 a	Test	Pressure HIGH-235			
Kompr.	kg 0,090	P.S.-I.	LOW 140			
Made in Italy 13918						

**Never call on unauthorized technicians and always refuse spare parts which are not originals.**

# Reversing the door opening

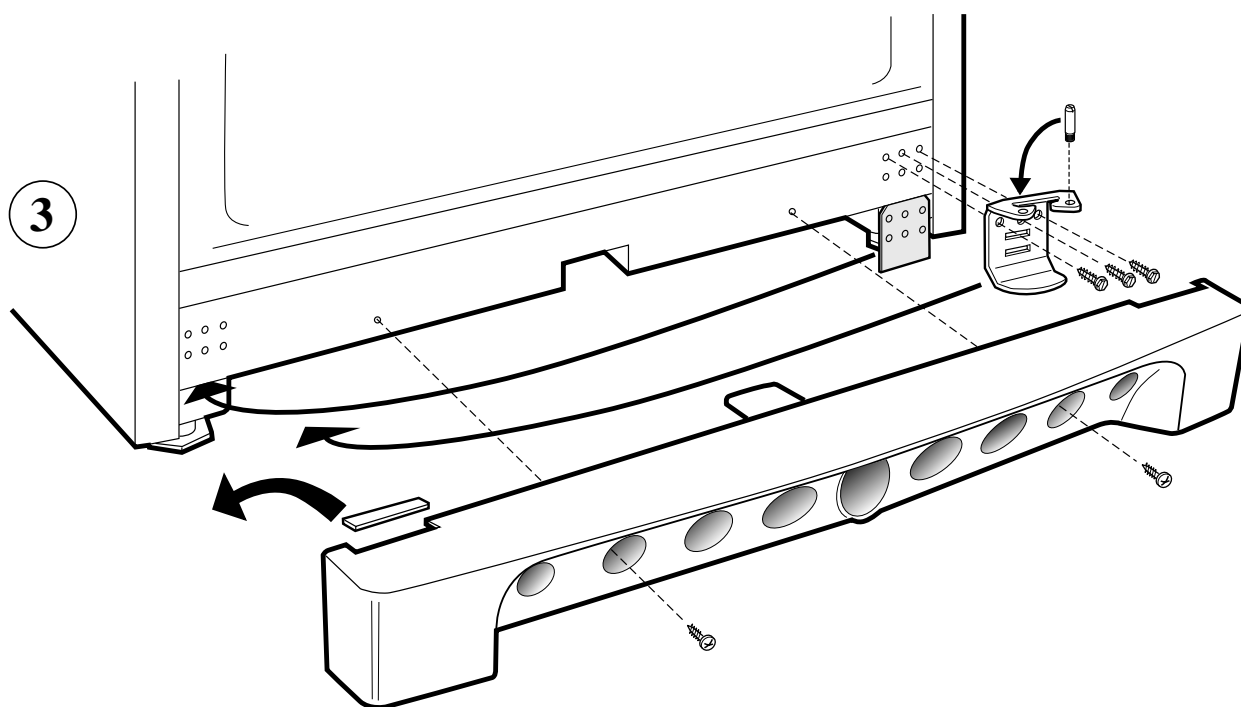
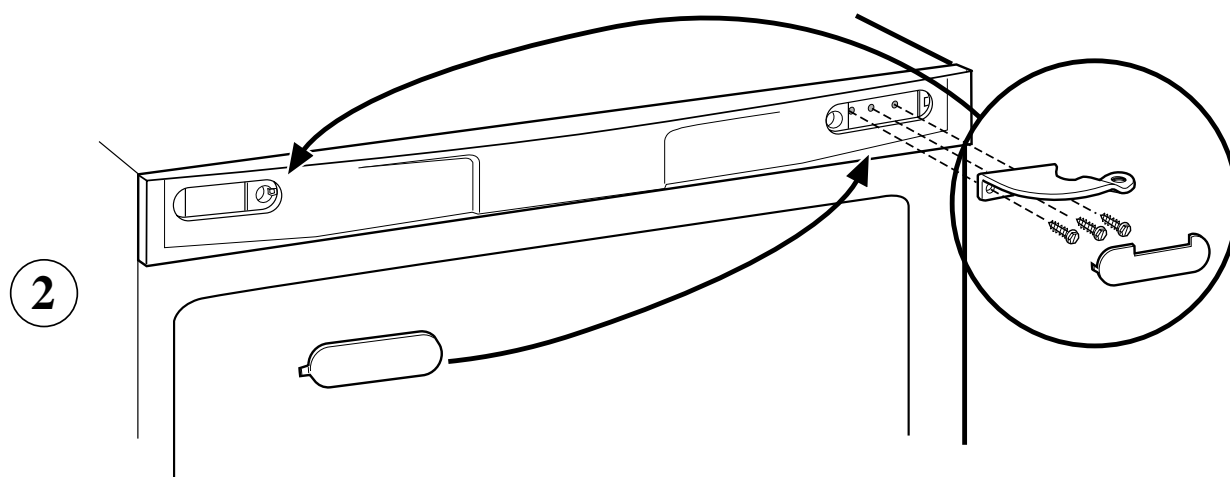
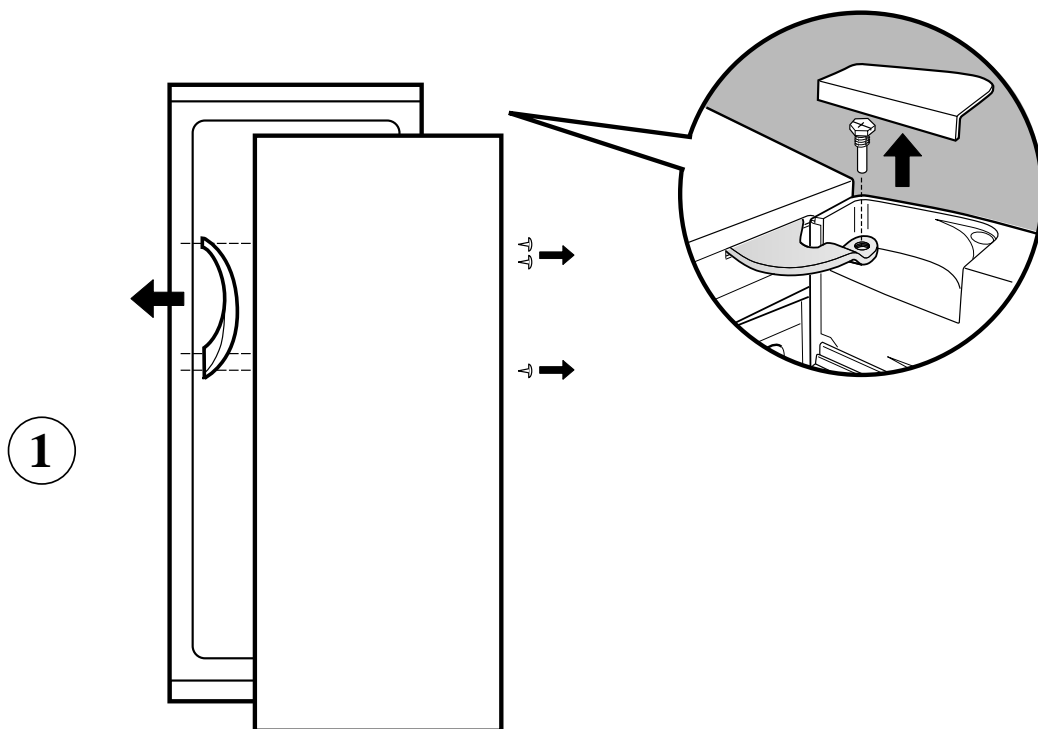

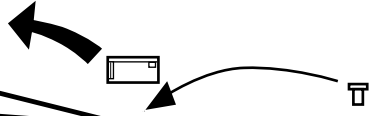
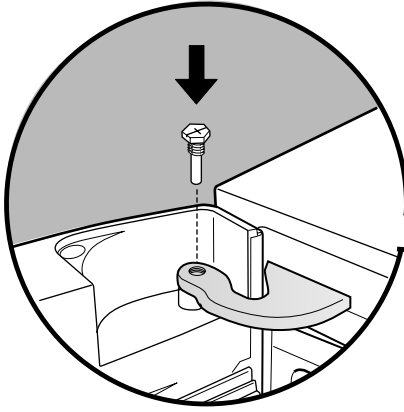

4

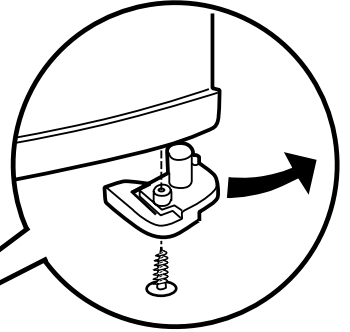
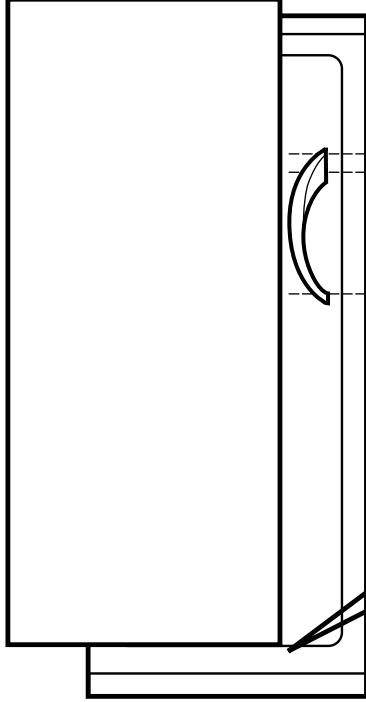
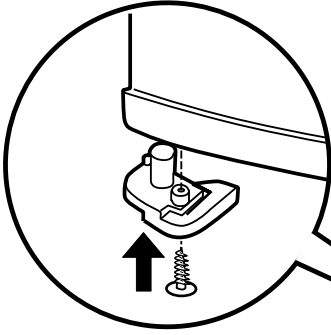

# Merloni Elettrodomestici

Viale Aristide Merloni 47

60044 Fabriano

Italy

Tel +39 0732 6611

Fax +39 0732 662501

[www.merloni.com](http://www.merloni.com)